

ZDF3尺寸图

ZDF3 SIZE CHART

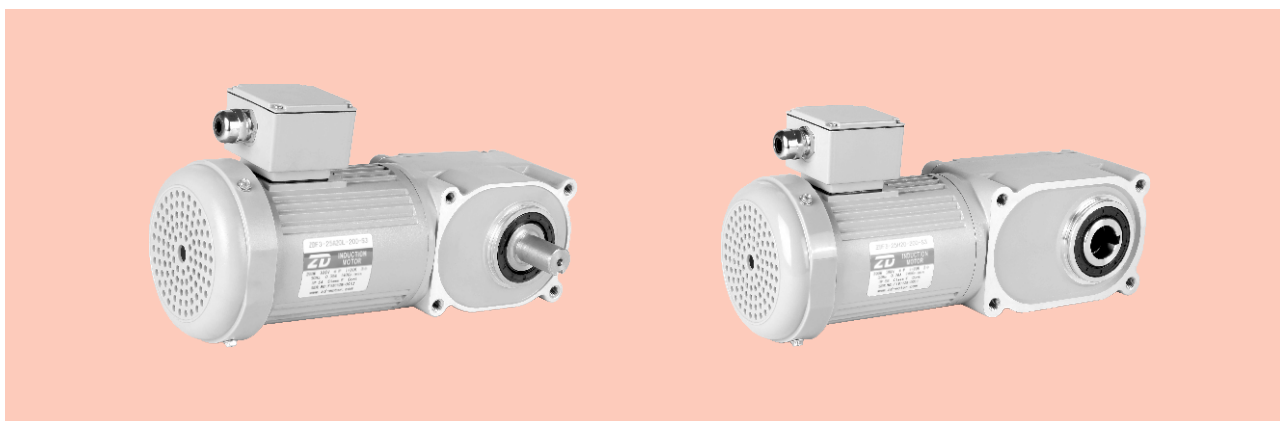

规格 · 连续额定 Specification And Continuous Rating

型号 Model	输出功率 Output Power	电压 Voltage	频率 Frequency	额定电流 Rated Current	额定转矩 Rated Torque	额定转速 Rated Speed	堵转转矩 Locked Rotor Torque	堵转电流 Locked Rotor Current	绝缘等级 Insulation Grade
	W	V	Hz	A	N.m	r/min	N.m	A	
ZDF3-25H□-200-S(B)	200	200	60	1.10	1.12	1700	2.25	4.93	F
ZDF3-30H□-200-S(B)		220	50	1.35	1.36	1400	3.50	5.40	
ZDF3-25H□-200-S ₃ (B)		380	50	0.78	1.36	1400	3.50	3.10	
ZDF3-30H□-200-S ₃ (B)		460	60	0.78	1.12	1740	3.80	3.75	

型号 Model	输出功率 Output Power	电压 Voltage	频率 Frequency	额定电流 Rated Current	额定转矩 Rated Torque	额定转速 Rated Speed	堵转转矩 Locked Rotor Torque	堵转电流 Locked Rotor Current	绝缘等级 Insulation Grade
	W	V	Hz	A	N.m	r/min	N.m	A	
ZDF3-22A□-200-S(B)	200	200	60	1.10	1.12	1700	2.25	4.93	F
ZDF3-28A□-200-S(B)		220	50	1.35	1.36	1400	3.50	5.40	
ZDF3-22A□-200-S ₃ (B)		380	50	0.78	1.36	1400	3.50	3.10	
ZDF3-28A□-200-S ₃ (B)		460	60	0.78	1.12	1740	3.80	3.75	

功率 Power	孔径/轴径 Aperture/Axis Diameter	减速比 Reduction Ratio	输出轴转速 Output Shaft Speed	输出轴容许转矩 Output Shaft Torque		输出轴容许 Output Shaft Tolerance		输出轴容许 Output Shaft Tolerance	
			r/min	N.m	kgf.m	N	kgf	N	kgf
W	mm	i	50Hz	50Hz	50Hz	N	kgf	N	kgf
200	25/22	5	300.0	5.5	0.560	1230	126	307	31
		7.5	200.0	8	0.790	1370	140	342	35
		10	150.0	11	1.130	1520	155	380	39
		12	125.0	13	1.350	1620	165	405	41
		15	100.0	17	1.690	1720	176	429	44
		20	75.00	22	2.260	1860	190	466	48
		25	60.00	28	2.820	2010	205	502	51
		30	50.00	33	3.380	2110	215	527	54
	30/28	40	37.50	44	4.510	2300	235	576	59
		50	30.00	55	5.640	2450	250	613	63
		60	25.00	66	6.770	2550	260	637	65
		80	18.80	80	8.120	3090	315	775	79
		100	15.00	99	10.15	3140	320	785	80
		120	12.50	119	12.18	3140	320	785	80
		160	9.400	159	16.24	3140	320	785	80
		※200	7.500	184	18.80	3140	320	785	80
※240	6.300	184	18.80	3140	320	785	80		

注：带※号的为转矩力限制机种，使用时请阅读本表。 Note: The number for the torque limit model, please read this table.

外形图 OUTLINE DRAWING

ZDF3-25H5~60-200-S(B) ZDF3-25H5~60-200-S₃(B)

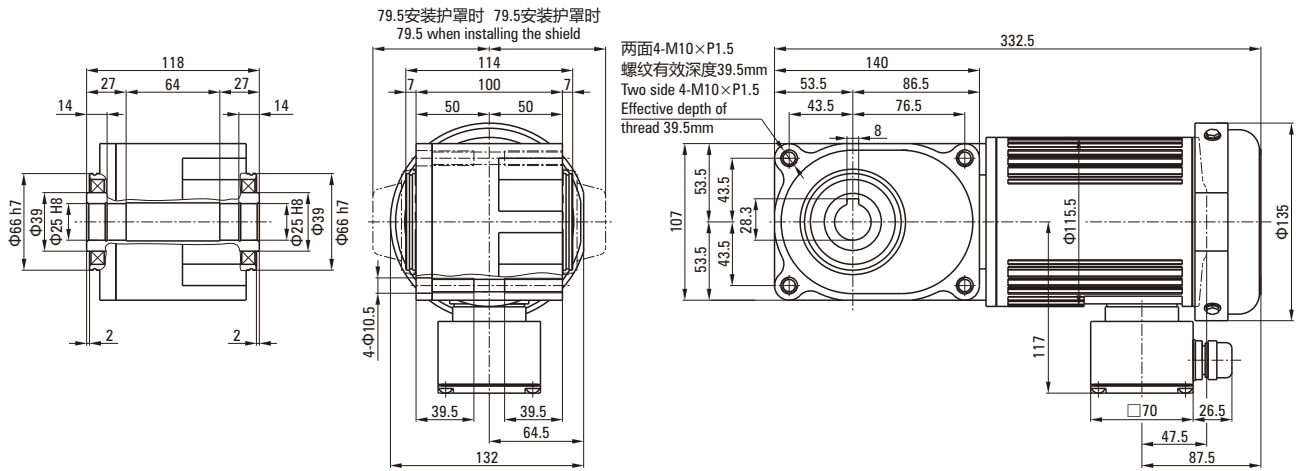

ZDF3-22A5~60_R-200S-(B) ZDF3-22A5~60_R-200-S₃(B)

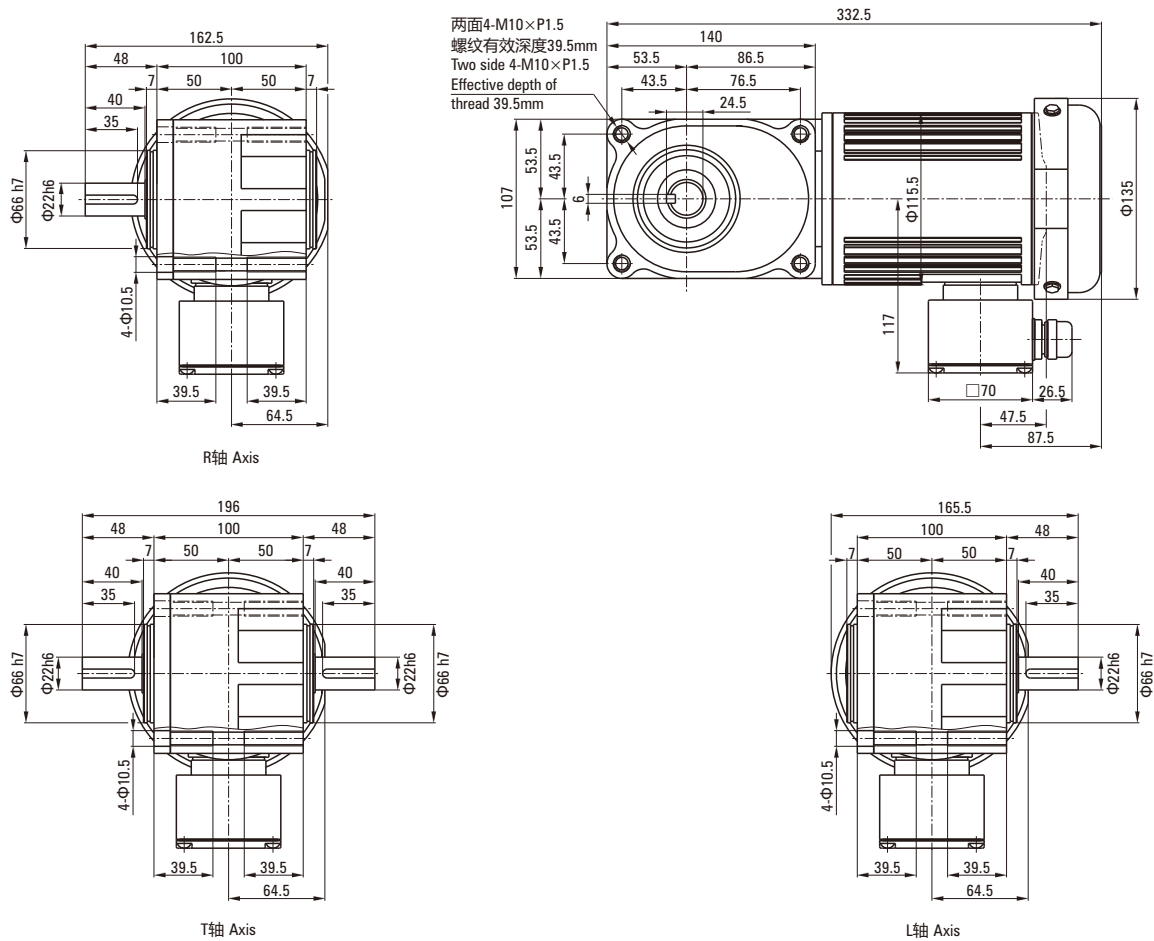

外形图 OUTLINE DRAWING

ZDF3-30H80~240-200-S(B) ZDF3-30H80~240-200-S₃(B)

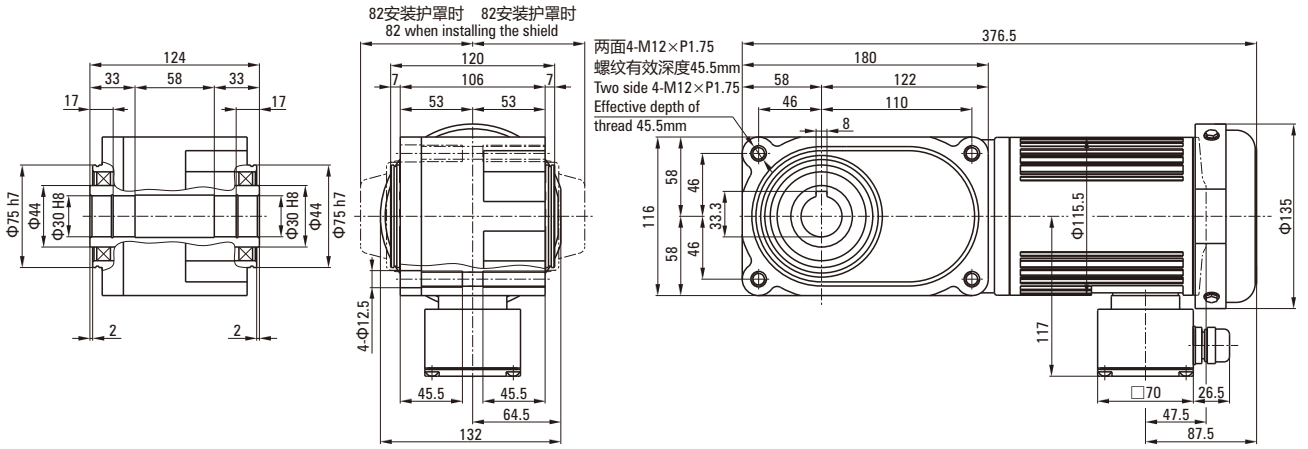

ZDF3-28A80~240R-200-S(B) ZDF3-28A80~240R-200-S₃(B)

